

Urban Energy Technical Note



Energy and Resource Efficiency Building Code. Guidelines.

The building code is a tool that interacts with the planning law and as such is a part of the authorities' resources whose purpose is to guarantee the right to sustainable cities and safeguard a healthy and comfortable urban environment. At the same time, it should provide valid solutions according to the local climate, social needs and transformations, local cultural identity and cultural practices.

The purpose of this technical note is to offer orientation to professionals and policy makers in tropical countries for the development of a comprehensive building code on Energy and Resource Efficiency in Building that ensures a healthy urban and building environment whilst promoting the recovery of the huge energy saving potential in the building sector.

The sections considered to be part of a comprehensive EREBC include:

- Appropriate criteria for the quality of the indoor environment
- Sustainable building design: building location and orientation, building configuration, envelope, solar protection, natural ventilation, passive solar heating, passive cooling, natural lighting and appropriate building materials.
- Building systems: including artificial cooling, space heating, solar water heating, mechanical ventilation, kitchen equipment, lifts and escalators and other electrical appliances

- Moisture control
- Renewable energy
- Water
- Sewage
- Waste management

Additional recommendations address sustainable interventions in the urban environment and neighbourhood planning including: guidelines on urban design, urban mobility and accessibility, sewer and waste management at a municipal level and landscaping on an urban scale.

Fig. 01: Scope

1. SCOPE	
1.1. Applicable building systems	
<p>The Energy and Resource Efficiency Building Code shall be applied in the following cases:</p> <ul style="list-style-type: none"> • New buildings • Additions to existing buildings • Alterations to existing buildings (restoration or alteration of equipment, electrical appliances and/or sewer system) • Buildings/parts of buildings permanently open and conditioned. • Mechanical systems and equipment: 	<p>cooling, heating, ventilation and air conditioning</p> <ul style="list-style-type: none"> • Service hot water heating • Interior/exterior lighting • Electrical power • Water facilities • Sewer/drainage systems • Solid waste management • Land, vegetation and landscaping • Site planning and urban planning



© UN-Habitat
Sustainable building for community purposes in Rwanda. Appropriate building design with adequate orientation, sun protection, natural ventilation, use of local materials, and water efficiency technologies like rainwater harvesting. Community buildings can function as showcases and promotion of sustainable building

Fig. 02: Guidelines for Energy and Resource Efficiency Building Code in Tropical Climates

2. PRESCRIPTIVE, TRADE-OFF OR PERFORMANCE OPTIONS

An Energy and Resource Efficiency Building Code can be based on different methods of measuring energy performance in buildings. Each path has advantages and disadvantages:

- **Prescriptive path:** is based on fixed U-values for each component of the building envelope in relation to the climate, the Window to Wall Ratio (WWR, proportion of window that remains un-shaded to wall ratio) and the maximum Solar Heat Gain Coefficient (SHGC) of glazing. It requires less effort but allows less design flexibility.
- **Overall Building Envelope Trade-Off option:** is based on the use of equations and tabulated reference values regarding the thermal transmittance values of the whole envelope and the equivalent WWR. This approach allows trade-off between building envelope components, so it provides more building design flexibility.
- **Performance path:** is based on the general energy performance of the building. A strict use of this method requires energy simulation software. The annual thermal heating and cooling energy requirements of the building shall be less than or equal to the annual thermal heating and cooling energy requirements (kWh/m²/year). It requires more effort to demonstrate compliance but allows greater design flexibility than the others.

3. ENERGY EFFICIENCY BUILDING DESIGN PRESCRIPTIONS

3.2.1. General conditions common to all climatic zones

- Buildings shall be designed according to the local climate
- Passive building design measures shall take precedence over mechanical means in order to achieve thermal and visual comfort and avoid unnecessary energy consumption. These measures are summarized in the following subsections.

ORIENTATION

- Main façades shall be oriented north – south in order to reduce heat loads.
- Less occupied spaces (corridors, service rooms) shall be located adjacent to the façade most exposed to solar radiation. More occupied spaces shall be adjacent to the less exposed façades .

BUILDING MATERIALS

- Building materials shall be, as far as possible, extracted and manufactured locally, have minimum embodied energy, and be recyclable or reusable after the building’s lifetime.

BUILDING ENVELOPE (ROOF, WALLS, FLOORS AND OPENINGS)

- Walls shall comply with the U-Values provided by the code according to climate (for prescriptive and Trade-off paths) and have a reflective external surface (light colour finishes) or reflective insulation in order to reduce solar heat loads.
- Roofs shall comply with the U-Values provided by the code (for prescriptive and Trade-off paths), and shall be insulated and/or ventilated in all tropical climates. The thermal transmittance of roofs shall not exceed 0.85 W/m² K in any case. The reflection coefficient for solar radiation of roofs must be as large as possible, preferably greater than 70%.
- Windows: glazing for vertical fenestration and skylight assemblies for prescriptive and Trade-off paths shall meet either the U-Values, Solar Heat Gain Coefficients (SHGC) and the Architectural Shading Factor (ASF) or the U-Values respectively. Vertical fenestration area is limited to a maximum of 45% of the gross wall area and skylight to 5% of the gross roof area for the prescriptive requirement.

Fig. 03: General Guidelines for Appropriate Orientation, Building Materials and Building Envelope

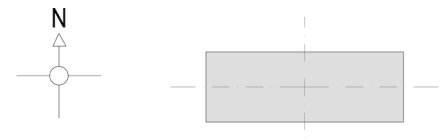

Building adequate orientation in tropical climates. Facades with the largest windows shall be oriented towards the North – South



Local building materials: Stone and stabilized soil blocks. © UN-Habitat (top); © Shortie (bottom)



Appropriate Window to Wall Ratio and horizontal shading devices. © UN-Habitat / UMU (top); © UN-Habitat / Zeltia Gonzalez Blanco (bottom)

- U-Values for roof, walls and openings or an overall U-Value shall be determined according to the prescriptive, Trade-off or performance based paths as per climatic zone.
- Building Envelope Sealing: in air-conditioned buildings, good insulation of the envelope is indispensable to reduce the energy consumption. The following areas shall be sealed to minimize air leakage: 1/ Joints around fenestration and door frames; 2/ Openings between walls and foundations/roof; 3/ Openings at penetrations of utility services through roofs, walls, and floors; 4/ Ducts or plenums; 5/ All other openings in the building envelope

NATURAL LIGHTING

- All buildings shall have adequate natural lighting and energy efficient lighting facilities according to the needs of the users, including any occupied room, staircases and corridors.
- Windows must be made, located and, where required, screened such that sunlight through them does not cause overheating in the rooms and glare is avoided.
- The effective area of daylight openings, i.e. their transparent area multiplied by their light transmission coefficient without mobile solar protections, shall be between 20% and 30% of the net floor area of the room.
- Note: 25% of WWR is the optimum rate for natural lighting. Beyond this value a sort of saturation is reached, while consumption for cooling continues to grow.
- Buildings of uses determined by the code whose floor area exceeds a certain m² shall provide a control system that optimizes the use of natural light minimizing artificial lighting.
- The distance between the work or stay places and the openings shall not exceed 3 times the height of the openings above the working place.
- The code shall provide the illuminance (in Luxes) requirements for every building use
- Light indoor colours shall be used to maximize natural lighting

NATURAL VENTILATION

- Natural ventilation shall take precedence over artificial ventilation when possible.
- In every occupied space, openings for natural ventilation shall be provided.
- Specifications for the minimum proportion of openings in relation to the net floor area to ensure good natural ventilation shall be provided for every building typology, kitchens and bathrooms.
- Solar chimneys for natural ventilation where passive ventilation is difficult should precede mechanical ventilation.

NATURAL COOLING

- Passive cooling shall take precedence over artificial cooling when possible.
- Openings provided in opposite walls. Exceptions are premises of less than 3 metres deep.

PASSIVE HEATING

- Passive heating shall take precedence over artificial heating, when possible.
- In climatic zones where the daily mean temperature may fall below the comfort range (18 to 20°C), every new or renovated building shall be designed to allow the use of a passive solar heating strategy.

Fig. 04: General Guidelines for Good Natural Lighting, Ventilation and Cooling

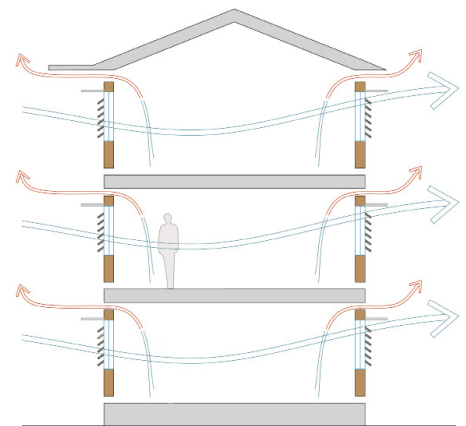

Natural Ventilation: horizontal or cross ventilation and vertical or stack ventilation



Natural lighting and natural ventilation through stack effect © UN-Habitat / Zeltia Gonzalez Blanco



Natural lighting in big infrastructures © UN-Habitat / Zeltia Gonzalez Blanco

3.2.2. Hot and Humid climate. Building design prescriptions

BUILDING CONFIGURATION

- Isolated long, narrow and open buildings to allow good cross ventilation

BUILDING MATERIALS

- Lightweight building materials with insulation properties in walls and roofs: light stone; thin concrete blocks or thin bricks (10 cm max); wood or bamboo; wattle and daub (10 cm max); other local materials with similar characteristics
- Where there is air conditioning: high insulation factor in walls and roofs (insulation layer in the inner part of the wall) and airtight openings.

OPENING SIZES AND SOLAR DEVICES TO AVOID OVERHEATING

- WWR: 20% to 45%. Large openings to allow ventilation, preferably horizontal to maximize ventilation air velocity.
- Openings in N/S façades maximized and minimized in E/W façades
- Small openings in the upper part of the wall
- Protection from solar radiation but allowing permeability: verandas, jalousie, awning and perforated walls.
- Openings in opposite walls for cross ventilation

BUILDING ENVELOPE (ROOF AND WALLS)

Roofs:

- Lightweight material and high reflectivity roofs insulated or separated from ceiling / open terrace to allow ventilation
- Vents just under the roof or on the roof to allow vertical ventilation
- Minimum floor-to-ceiling height of 3 m

Walls:

- Lightweight materials to prevent heat storage
- High ceilings to promote stratification of air
- Grills at the ground floor and at the top of exterior walls for vertical ventilation
- Protection from solar radiation (cavity walls for non-shaded elevations, hollow block walls, overhangs & verandas, trees)
- Light coloured exterior and interior finishes to reflect solar radiation and enhance natural lighting

NATURAL VENTILATION

- Maximization of horizontal and vertical ventilation: large openings, vents at floor and roof level, opposite openings in different axes to maximize cross ventilation, and ventilated roof

NATURAL COOLING

- Maximization of ventilation
- Indirect evaporative cooling

Fig. 05: Guidelines for Building Design in Hot and Humid Climates

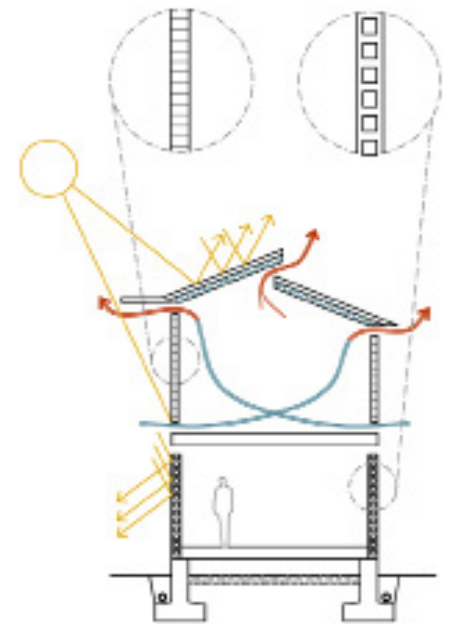
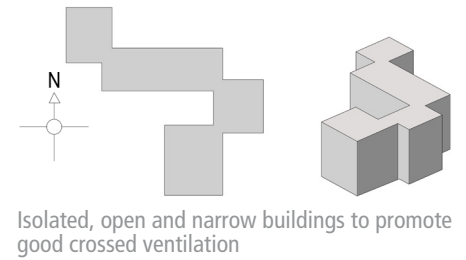

Light weight walls and well insulated and ventilated roof

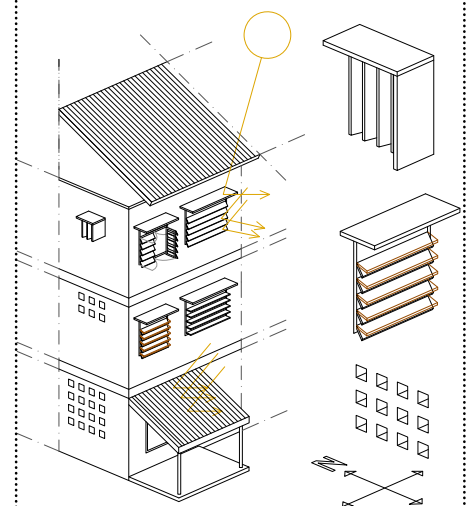

Moveable solid louvers, verandas and perforated walls to allow ventilation. Photo: © UN-Habitat / Ardhi University

3.2.3. Semi-arid / Savannah climate. Building design prescriptions

BUILDING CONFIGURATION

- Long, narrow semi-open buildings to allow good cross ventilation

BUILDING MATERIALS

- Medium weight building materials but with insulation properties in walls and roofs: medium weight stone, concrete blocks or bricks (20 cm max), wattle and daub, soil stabilized blocks (20 cm max), other local materials with similar characteristics
- Where there is air conditioning: High insulation factor in walls and roofs (insulation layer in the inner part of the wall) and airtight openings

OPENING SIZES AND SOLAR DEVICES TO AVOID OVERHEATING

- WWR: 20% to 30%. Medium openings
- Openings in N/S façades maximized and minimized in E/W façades
- Protection from solar radiation. Make sure shading devices do not cause glare.
- Small vents, in the upper part of the wall
- Openings in opposite walls for cross ventilation
- Ventilation limited during daytime to avoid hot air and increased at night when the air is cool.

BUILDING ENVELOPE (ROOF AND WALLS)

Roofs:

- Mid-weight material with high reflectivity
- Openings to allow vertical ventilation at night (vents just under the roof or on the roof).

Walls:

- Medium-weight materials
- Solar protection (overhangs and verandas, trees and bushes)
- Light coloured exterior and interior finishes to reflect solar radiation

NATURAL VENTILATION

- Horizontal and vertical ventilation
- Vents at roof level to release hot air
- Opposite openings in different axes to maximize cross ventilation
- Ventilated roof

NATURAL COOLING

- Maximization of ventilation and indirect evaporative cooling

3.2.4. Highland – Upland climate. Building design prescriptions

BUILDING CONFIGURATION

- Compact buildings to protect buildings from cold weather

BUILDING MATERIALS

- Medium-weight building materials with insulation properties in walls and roofs: medium weight stone, 20-30 cm concrete blocks, 20-30 cm bricks, wattle and daub, 20-30 cm soil stabilized blocks, rammed earth, adobe, other local materials with similar characteristics.
- In case of artificial heating (at very high altitudes), heavy weight building materials with high insulation factor should be provided.

Fig. 06: Guidelines for Building Design in Semi-arid/Savannah Climates

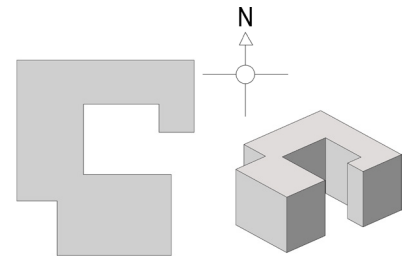

Semi-open buildings to protect from solar radiation whilst promoting natural ventilation

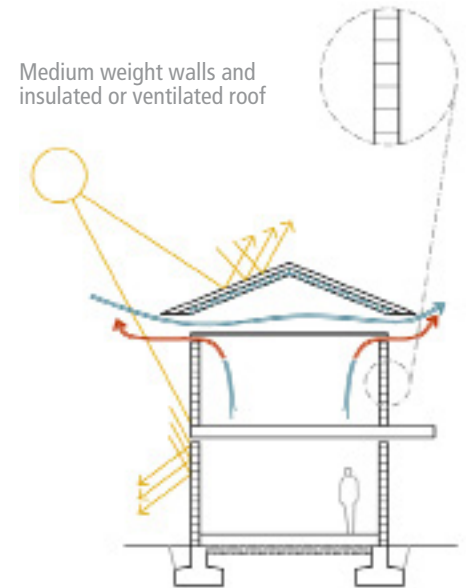

Medium weight walls and insulated or ventilated roof



Permanent ventilation in building in Savannah Climate. Uganda. © UN-Habitat / UMU

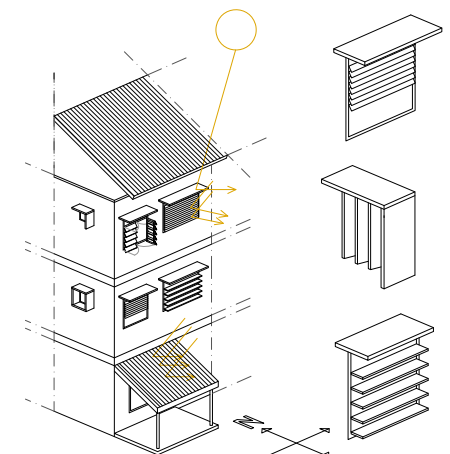

Louvered shutters and verandas allow ventilation and sun protection. Venetian blinds placed outside

OPENING SIZES AND SOLAR DEVICES TO AVOID OVERHEATING

- Openings sized according to orientation in order to optimize solar heat gains and heat losses.
- Openings protected from solar radiation in the hot season but letting sun in during the cold season.
- Openings in opposite walls for cross ventilation
- Window frames should be airtight: casement type is optimal for this climate

BUILDING ENVELOPE (ROOF AND WALLS)

Roofs:

- Mid-weight material, mid- thermal capacity
- Medium reflectivity
- Insulated roofs or roofs with air chamber

Walls:

- Medium to high weight materials with thermal mass to store heat in the colder season
- Light coloured exterior and interior finishes to reflect solar radiation

NATURAL VENTILATION

- Horizontal ventilation:
- WWR from 20% to 25%.Medium openings
- Opposite openings in different axes to maximize cross ventilation
- Ventilated roof is recommended but not essential

NATURAL COOLING

- Good natural ventilation strategies are enough to cool indoor environment

PASSIVE HEATING

- Passive heating through building materials with high thermal mass and adequate orientation

3.2.5. Lakes Region climate. Building design prescriptions

BUILDING CONFIGURATION

- Isolated long, narrow and open buildings to allow good cross ventilation

BUILDING MATERIALS

- Medium to heavy weight building materials with insulation properties in walls and roofs: medium weight stone, concrete blocks or bricks (20 cm and above), wattle and daub, soil stabilized blocks, rammed earth, adobe, other local materials with similar characteristics
- Where there is air conditioning: high insulation factor in walls and roofs and airtight openings

OPENING SIZES AND SOLAR DEVICES TO AVOID OVERHEATING

- Large openings to allow ventilation, preferably horizontal to maximize ventilation air velocity.
- Openings in N/S façades maximized and minimized in E/W façades
- Protection from solar radiation but allowing permeability: verandas, jalousie and awning.
- Openings in opposite walls for cross ventilation

BUILDING ENVELOPE (ROOF AND WALLS)

Roofs:

- Mid-weight material, mid- thermal capacity
- High reflectivity

Fig. 07: Guidelines for Building Design Highland Climates

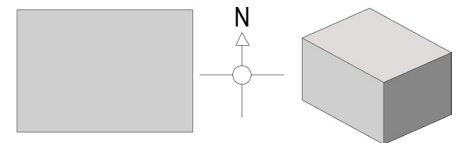

Compact buildings to protect from low temperatures during cold season and night.

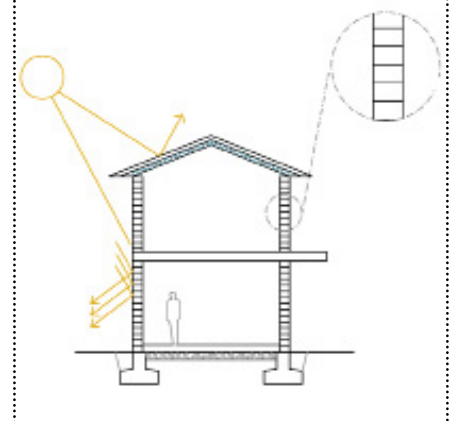

Medium to high weight walls to store heat during the day and release it during the night and insulated roof to protect from solar radiation. Photo: © UN-Habitat / Zeltia Gonzalez Blanco

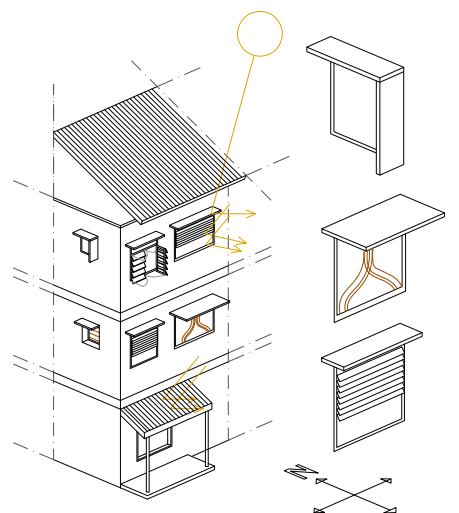

Overhangs and fins, adjustable louvers outside, venetian blinds and curtains inside

- Insulated roofs or roofs with ventilated air chamber
- Vents provided just under the roof or on the roof to allow vertical ventilation

Walls:

- Medium to high weight materials to store heat during the day and release it during the night
- High ceilings to promote stratification of air
- Operable grills at ground level and at the top of exterior walls for vertical ventilation
- Solar radiation protection (overhangs and verandas, trees)
- Light coloured exterior and interior finishes to reflect solar radiation

NATURAL VENTILATION

- Horizontal and vertical ventilation
- WWR from 25% to 40%. Medium to large openings
- Vents at roof level to release hot air
- Opposite openings in different axes to maximize cross ventilation
- Ventilated and insulated roof

NATURAL COOLING

- Maximization of ventilation and indirect evaporative cooling

PASSIVE HEATING

- Passive heating through building materials with high thermal mass and adequate orientation

Fig. 08: Guidelines for Building Design in Lake Region Climates

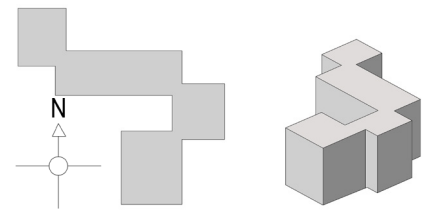

Building configuration: Open and narrow buildings to promote good crossed ventilation

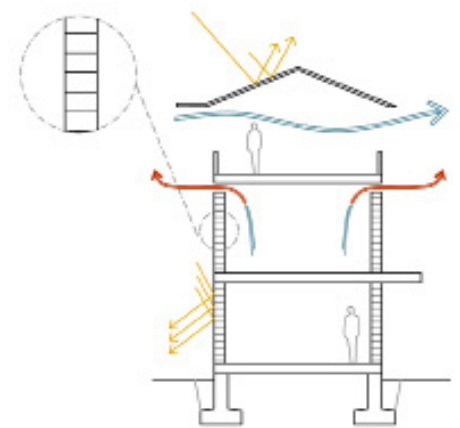

Building envelope: Medium weight walls to provide passive heating at night and protect from solar radiation during day time and well insulated and ventilated roof

3.2.6. Hot and arid climate. Building design prescriptions

BUILDING CONFIGURATION

- Compact buildings with courtyard to allow good natural ventilation and protect from high temperatures

BUILDING MATERIALS

- Heavy weight building materials in walls and roofs: heavy weight stone (thick walls), concrete blocks (30 cm and above), bricks (30 cm and above), wattle and daub, rammed earth, adobe, soil stabilized blocks (30 and above), other local materials with similar characteristics
- Air conditioning should not be necessary with an appropriate building design. However, in cases where it is needed, there should be a high insulation factor in walls and roofs and airtight openings

OPENING SIZES AND SOLAR DEVICES TO AVOID OVERHEATING

- WWR 15 to 25%. Many small openings, better than large ones to prevent solar radiation
- Openings in N/S façades maximized and minimized in E/W façades
- Protection from solar radiation. Make sure shading devices do not cause glare.
- Openings in opposite walls for cross ventilation at night
- Ventilation limited during daytime to avoid hot air and increased at night

BUILDING ENVELOPE (ROOF AND WALLS)

Roofs:

- Heavyweight materials
- High reflectivity



Building protected with solar devices in Lake Region. Uganda © UN-Habitat / UMU

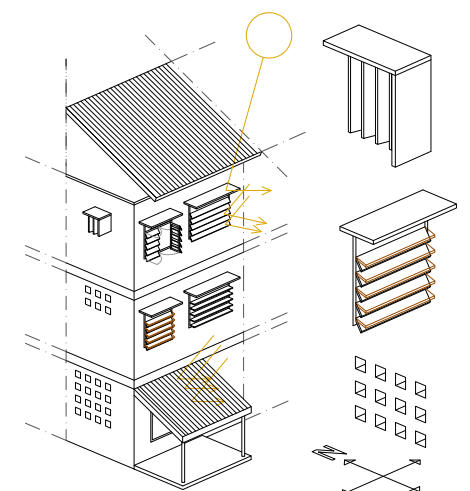

Moveable solid louvers, verandas and perforated walls to allow ventilation and sun protection.

- Openings to allow vertical ventilation at night (vents just under the roof or on the roof).
- Ventilated roof, flat roof or dome are appropriate for this climate

Walls:

- Heavyweight materials with thermal inertia to prevent heat transmittance during daytime
- Thick high thermal mass walls or high thermal mass walls with exterior insulation
- Solar protection (overhangs and verandas, trees and bushes)
- Light coloured exterior and interior finishes to reflect solar radiation

NATURAL VENTILATION

- Horizontal and vertical ventilation
- Courtyard with vegetation and water bodies and protected from solar radiation to keep the building cool throughout the day.
- Openings closed during the day and opened at night to cool the building through evaporative cooling
- Small openings in the outside walls and bigger openings facing the courtyard
- Opposite openings in different axes to maximize cross ventilation at night through evaporative cooling

NATURAL COOLING

- Evaporative cooling by maximization of ventilation during night time

PASSIVE HEATING

- Passive heating through use of building materials with thermal mass

4. PRESCRIPTIONS FOR BUILDING APPLIANCES

4.1. Heating, mechanical ventilation and air conditioning

- Only in cases where natural ventilation is insufficient should artificial ventilation systems be implemented. Minimum air requirements for artificial ventilation in buildings shall be provided in the code according to the room use.
- Envelopes of buildings equipped with mechanical ventilation shall be airtight.
- Airflow rate shall be increased from 3 to 4 volumes per hour or from 9 to 12 m net floor area if the glazing-to façade area ratio exceeds 30%, due to increased heat gains.
- Mechanical ventilation facilities of heated or cooled premises shall have supply and return ducts with enthalpy recovery, unless it is proven that energy recovery is not profitable.
- The effective airflow rates, pressure differentials and energy efficiency of fans shall be measured and compared to the design values.
- The overall annual coefficient of performance (COP) of cooling facilities shall exceed 3.8.
- The code shall provide the minimum efficiency requirements for the cooling equipment.
- Piping for heating systems shall have insulation according to the design operating temperature.

Ceiling Fans:

- The code shall provide the appropriate fan diameter in function of the space area in order to provide adequate ventilation.

Fig. 09: Guidelines for Building Design in Hot and Arid Climates

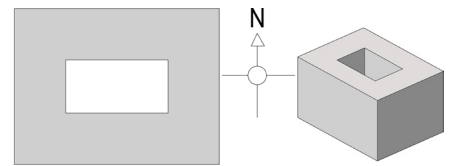

Compact buildings with patio to protect from high temperatures during daytime and promote evaporative cooling

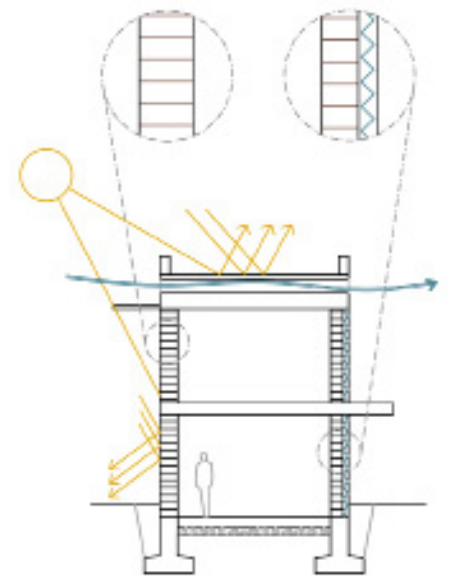

High weight walls to provide thermal mass and insulated and ventilated roof



Natural cooling through wind catcher towers
© UN-Habitat / Zeltia Gonzalez Blanco

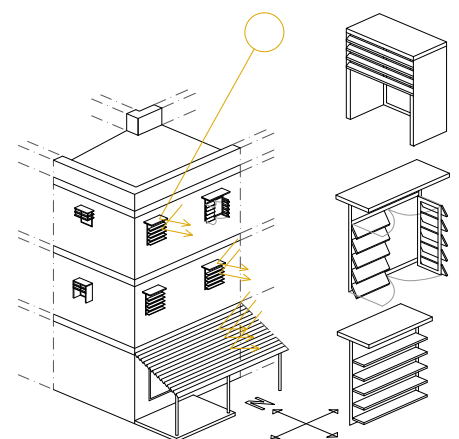

Verandas allowing ventilation and sun protection. Venetian blinds in the external side of the openings

AC:

- Mechanical cooling facilities are subject to authorization. This authorization may be granted only in hot-humid areas or if the internal heat loads accumulated over 24 hours exceed 160 Wh/m² net floor area.
- Mechanical cooling cannot be justified by thermal loads due to solar radiation or insufficient thermal insulation.
- The sizing of a mechanical cooling system shall be based on the following conditions: 1/ Airflow rate per person: between 10 and 30 m³/h; 2/ Internal operative temperature 25 °C; 3/ Indoor relative humidity 70%; 4/ Climatic condition.

Artificial Heating:

- Solid, liquid and gaseous fuel stoves shall be in a closed combustion room with adjustable air inlet. Flue gas must be evacuated by a flue gas duct outside the occupied space.

4.2. Electric lighting

- Lighting control requirements shall be specified to ensure that lights can be switched off when not needed, and to allow daylight energy saving strategies to be implemented.
- All lighting systems except those required for emergency or exit lighting should be provided with manual, automatic or programmable controls. For lighting loads exceeding 100 kW, automatic controls should be provided.
- The electrical lighting of offices, meeting rooms, teaching rooms, hotel rooms, etc. shall be equipped with a system which switches off the lighting in the absence of occupants.
- Luminous efficacy requirements shall be provided by the code according to the space use.

4.3. Kitchen equipment

- Wood-burning cooking stoves shall be in a closed combustion room with an adjustable air inlet. Flue gas shall be directly evacuated outside the occupied space with a duct.
- Hoods evacuating gases and aerosols shall be installed above every fuel stove. The evacuation of the gases can be natural (stack effect) or mechanical.

5. ELECTRICAL POWER

5.1. Minimum photovoltaic (PV) contribution to electric power

- Buildings established in this section of the Code shall incorporate photovoltaic solar energy systems for capturing and transforming solar energy into electricity for own use or supply to the network.
- New buildings and extensions of existing buildings exceeding 5000 m² with commercial, health, institutional or leisure use shall incorporate capture and conversion photovoltaic systems to transform solar energy into electricity.
- The different solar radiation zones in the country shall be established in the Code.
- A required minimum of electric power produced by solar photovoltaic systems shall be established in the Code according to the different solar radiation zones.
- The required minimum electrical power from solar photovoltaic systems may be either partially or completely replaced by production from other renewable energies.
- The layout of the modules will be such that losses due to orientation and tilt of the system and the shadows projected over it are less than the limits established in the Code.
- To ensure performance, increase reliability and extend the life of the systems required during the life of the facility, two complementary actions shall be defined and provided: 1/ monitoring plan; 2/ maintenance plan.

Occupancy	Minimum air required l/s
Kitchens	50.0 per local
Bedrooms	5.0 per occupant
Living rooms and dining rooms	3.0 per occupant
Bathrooms and shower-rooms	15.0 per local
Storage rooms and common areas	0.7 per m ² useful
Rooms containing WC pan or urinal	15.0 per local
Parking and garages	120 per parking space

Minimum l/s air exchanges required for artificial ventilation according to the space use



The Code shall encourage the use of low energy consumption lighting appliances



Installation of photovoltaic panels in the roof. Note: the limited losses allowed by orientation tilt and shading shall be the same than for solar water heating panels © UNDP

Type of Use (buildings or over 5000m ²)
Hypermarket
Shopping Mall and leisure center
Storage warehouse
Administration building
Hotel and hostel
Hospital and clinic
Exhibition Center

Scope of mandatory application of solar photovoltaic systems according to the building use

6. ACOUSTIC COMFORT

- Any building should be insulated from external noise in order to preserve indoor comfort and healthy environment. Background noise levels in occupied premises shall not exceed the levels established in the Code. It shall in no case exceed 85 dB (on 10 seconds average).
- Reverberation time shall be adapted to occupants activities.

7. MOISTURE CONTROL

- The building shall be designed and built so that there is no surface condensation of water vapour nor risk of mould growth in occupied spaces.
- The risk assessment provided by any project must take into account the transport of moisture by: 1/ convective air flows; 2/ capillarity; 3/ diffusion of water vapour.
- Spaces with important sources of humidity (kitchens, bathrooms, etc.) shall be sufficiently ventilated (naturally or mechanically), so as to evacuate the water vapour produced quickly.
- To avoid the risk of mould growth, the relative humidity of the air near the surface shall not exceed 80% for a period of more than two consecutive weeks.
- The thermal resistance of building must not decrease under the influence of moisture.

8. WATER FACILITIES. WATER EFFICIENT MANAGEMENT AND USE

8.1. Water efficiency and conservation measures

The Building Code shall establish water efficiency and conservation measures in buildings. These measures shall include:

- Integrating water efficiency and conservation measures into all building typologies: Water efficient fittings, water reuse practices that include rainwater harvesting and recycled grey water.
- Metering of existing multi-unit residential, commercial, and industrial complexes.
- Retrofitting of fixtures, equipment, and irrigation systems to make them more water efficient.
- Landscaping in a manner that conserves water use and is regionally appropriate.
- Monitoring plan to perform regular checks on plumbing systems to check for leakages, wastage, and system degradation.

8.2. Solar Water Heating (SWH)

- The aim of a thermal solar system is to provide the user with a solar installation that: 1/ optimises the global energy supply of the installation in combination with the rest of the building’s thermal equipment; 2/ guarantees sufficient durability and quality; 3/ guarantees safe use of the installation
- The Building Code shall establish the minimum solar contribution according to the solar radiation zone and the maximum losses allowed according to orientation, tilt and shade.
- The Building Code shall provide guidance on the calculation of the demand and sizing of the solar water heater system according to the requirements.
- The Building Code shall establish the requirements for overheating and fire protection, working fluid, resistance to pressure, backflow prevention, tank and piping insulation.
- All building projects with a SWH system shall provide a surveillance and maintenance plan that includes all the operations necessary during the life of the installation in order to ensure efficiency and operability, to increase reliability, and to prolong the duration of the system.

Type of use / Activity	Maximum background noise levels (dBA)
Residential	35 (night) – 45 (day)
Sleeping rooms	30 - 40
Small offices and meeting rooms	30 - 40
Large offices to open, busy offices	40 to 60
Intellectual work	50 - 70
Manual work (e.g. in factory buildings)	80
Noise from ventilation systems	30

Maximum allowed background noise levels (dBA)



An average of 30% of water used in cities is wasted due to leakages in the distribution system © Pulpolux



The Building Code shall provide the minimum mandatory contribution for solar water heating © UN-Habitat / Zeltia Gonzalez Blanco

Case	Total maximum losses
General	15 %
Superposition	30 %
Architectural integration	50 %

Limited energy losses of solar water heating by orientation tilt and shading. The optimal orientation and tilt shall be calculated according to the latitude

8.3. Grey water reuse and recycling

- Suitable systems that utilise recycled grey water shall be encouraged for purposes that are not for human consumption like flushing, washing, gardening, landscaping, among others.
- Grey water facilities shall be authorised in consultation with the local health authorities, and any wastewater service shall comply with water and health regulations.
- The Building Code shall provide the requirements for grey water recycling and reuse.

8.4. Rainwater harvesting

- Suitable systems that utilise rainwater harvesting shall be encouraged for purposes that are not for human consumption like flushing, washing, gardening, landscaping, among others
- Roof - Rainwater should only be collected from roofs and stored in cisterns. Rainwater run-off from outdoor surfaces typically contains contaminants which are undesirable.
- The Building Code shall provide the requirements for rainwater harvesting including: 1/ materials for roofing, drain, down pipe and storage tank; 2/ design and installation requirements; 3/ storage requirements; 4/ maintenance plan

9. DRAINAGE AND STORM WATER MANAGEMENT

- Treatment of storm water run-off before discharge into public drains shall be encouraged.
- Attempts should be made through sustainable drainage practices to restore the permeability index of the catchment to pre-development levels.
- The potential impact of new and existing developments with respect to surface water drainage discharges shall be mitigated through: 1/ source control; 2/ permeable paving; 3/ storm water detention; 4/ storm water infiltration; 5/ evapo-transpiration (e.g. from a green roof). The Code shall provide the requirements for these methods.
- Comprehensive storm water management with green storm water infrastructure must be given priority. Among other possibilities are bio-retention, permeable pavement and/or roof disconnection.
- Cleaning of drainage is a very important part of routine operation and maintenance. Cleaning should be done at least three times a year.
- The disposal of any materials other than storm water, such as waste, pollutants or water containing pollutants that can affect the water quality shall be prohibited and controlled.

10. SEWER SYSTEMS

- New buildings shall be located near existing infrastructure in order to increase efficiency and minimize urban sprawl.
- Separation of combined sewers shall be encouraged and implemented when possible.
- The use of non-mains foul drainage, such as wastewater treatment systems or cesspools, should only be considered where connection to main drainage is not practicable.
- In buildings far from the main sewer line or with difficult access to it, on-site sewage systems like biogas plants or reedbeds combined with septic tanks shall be encouraged.
- On-site sewage treatment systems must include primary and secondary treatment.
- Provisions and requirements for septic tanks, wetlands (i.e. reedbed systems), packaged treatment works, cesspools and biogas plants shall be provided in the Code, as well as the methodology to calculate the storage capacity of these systems. Specific provisions for wastewater treatment shall be provided so as to protect public health and the natural environment.
- A maintenance plan in the case of independent sewer systems shall be provided.



Rainwater harvesting to collect, convey and store rainwater from roofs © UN-Habitat

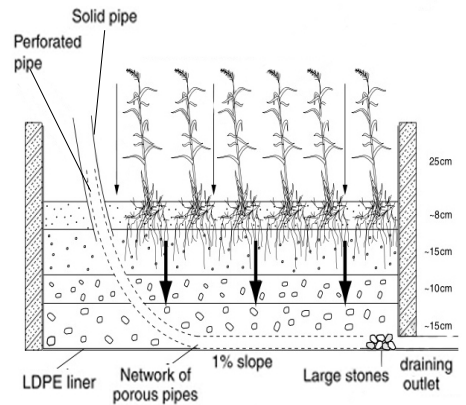

Key

'Sharp' sand	12mm round, washed gravel
6mm washed pea gravel	30-60mm round, washed gravel

Constructed wetland. Horizontal flow reedbed for waste water treatment



Biogas tank under construction in informal settlement where there is no access to sewer © UN-Habitat / Zeltia Gonzalez Blanco



Waste sorting in a paper recycling industry © UN-Habitat / Zeltia Gonzalez Blanco

11. SOLID WASTE MANAGEMENT

- Every multi-storey building or groups of single dwellings (groups of 10 households and more) shall be equipped with containers for selective harvesting of at least the following waste: 1/ glass; 2/ paper and paperboard; 3/ plastics and metals; 4/ organic waste.
- New multi-storey buildings or groups of single dwellings in the same compound shall provide a designated room for disposal and sorting of garbage.
- Bin rooms shall be provided with a notice explaining how waste separation should be done.
- In existing buildings and areas of isolated single dwellings the competent local authority shall provide a place for the containers in the urban space. Every waste collection point shall be accessible for motorized transport.

12. LAND, VEGETATION AND LANDSCAPING

12.1. Vegetation

- Use of local plants and trees adapted to the local climate and requiring minimal irrigation shall be encouraged for landscaping.
- Restoration, conservation or relocation of existing trees on site shall be encouraged.
- New buildings and existing buildings shall employ water-wise garden techniques (sometimes known as xeriscaping) to conserve water and reduce waste.
- New buildings and existing buildings shall encourage the implementation of systems that use grey water for gardening, irrigation or other non drinking purposes.
- Energy-efficient landscape design in the form of proper placement and selection of shade trees and creation of wind breaks shall be implemented in all building endeavours.

12.2. Paving

- Building endeavours shall incorporate permeable paving materials to reduce storm-water run-off and allow rain water to infiltrate into the ground and replenish groundwater.

12.3. Landscape lighting

- Building endeavours shall encourage the use of renewable energy in landscaping such as solar-powered landscape lighting.

Use of trees and vegetation according to climate

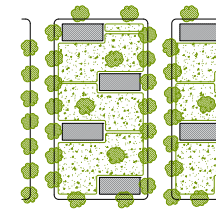
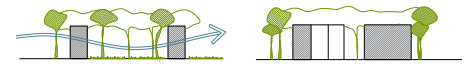

Hot and humid / Great Lakes: high trees to allow natural ventilation and provide shade to East and West facades. Vegetation cover to avoid overheating of pavement

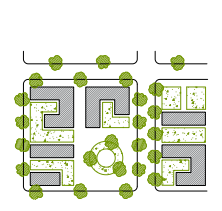

Semi arid: high- medium trees to provide sun shading and allow natural ventilation. Vegetation cover to avoid overheating of street pavement

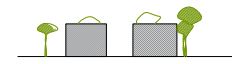

Highlands: medium- high trees to protect the urban space from overheating but allowing some solar radiation in the colder season. Vegetation cover to minimize overheating of pavement

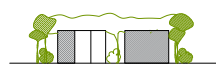

Hot and arid: Dense vegetation to protect the building from overheating (High trees and bushes). Vegetation cover to enhance evaporative cooling at night.



Example of permeable paving to promote water natural infiltration © Ron Mader

REFERENCES

United Nations Human Settlements Programme (UN-Habitat), *Energy and Resource Efficiency Building Code for Tropical Countries. Guidelines*

United Nations Human Settlements Programme (UN-Habitat), (2015). *SUSTAINABLE BUILDING DESIGN FOR TROPICAL CLIMATES, Principles and Applications for Eastern Africa.*

For more information, please contact:

The Urban Energy Unit
 Urban Basic Services Branch
 United Nations Human Settlements Programme (UN-HABITAT)
 P. O. BOX 30030 - 00100 Nairobi, Kenya
 Vincent.Kitio@unhabitat.org
 www.unhabitat.org/urban-themes/energy/

Executed by UN-Habitat with the support of GEF and UNEP



The purpose of this Technical Note is to call reader's attention to new technical issues in the field of sustainable human settlements development. They are not meant to be final or exhaustive. For more information, contact the Urban Energy Unit. Prepared by Zeltia González Blanco and Vincent Kitio.